

CAD FILE:

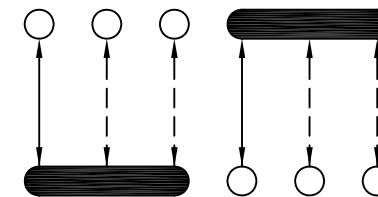

**SCHEMATIC (SHORTING)**

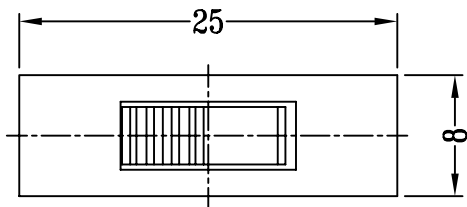
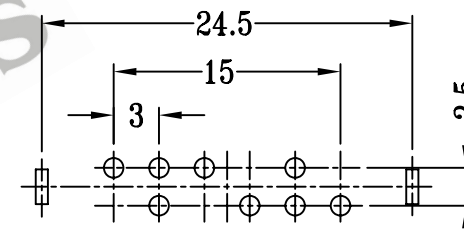
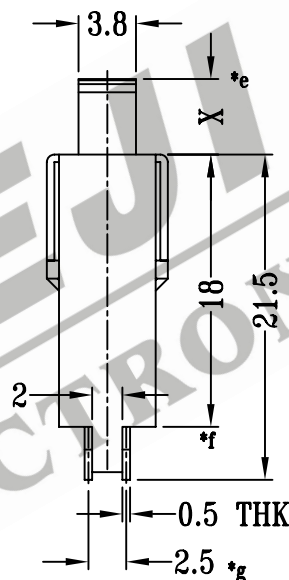
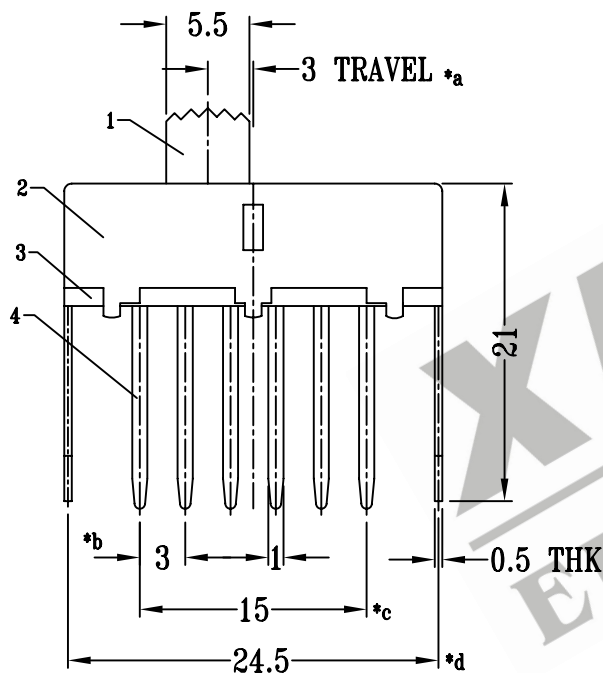

**P.C.B LAYOUT**

注:带"\*"表示关键尺寸(7个)

|     |              |                |      |                          |   |                                      |                            |                          |           |       |
|-----|--------------|----------------|------|--------------------------|---|--------------------------------------|----------------------------|--------------------------|-----------|-------|
| 8   |              |                |      |                          | TOLERANCE<br>UNLESS SPECIFIED           | SHENZHEN XIEJIA ELECTRONICS CO.,LTD. |                            |                          |           |       |
| 7   | STEEL BALL   | STEEL          | 2    | NATURAL                  |   |                                      |                            |                          |           |       |
| 6   | SPRING       | STEEL WIRE     | 3    | TEMPER                   | WITHIN: 1.5±0.1mm<br>OVER : 1.5±0.2mm   | ISSUE                                | DATE                       | DESCRIPTIONS OF REVISION |           | APPD. |
| 5   | CONTACT CLIP | BRASS STRIP    | 2    | Ag PLATED                |   |                                      |                            |                          |           |       |
| 4   | TERMINAL     | BRASS STRIP    | 8    | Ag PLATED OVER Ni PLATED | TITLE : VERTICAL SLIDE SWITCH           | UNIT : mm                            | DRWG NO.: XJ-DR-SS23F16-00 |                          |           |       |
| 3   | BASE         | PHENOLIC RESIN | 1    | BLACK                    |   |                                      |                            |                          |           |       |
| 2   | FRAME        | STEEL STRIP    | 1    | Ni PLATED                | MODEL: SS-23F16                         | SCALE: 2:1                           | DWN.                       | ZHOUYU                   | 2004-7-26 |       |
| 1   | KNOB         | POM            | 1    | BLACK                    |   |                                      | CHK'D                      | FANGYING                 | 2004-7-26 |       |
| NO. | PARTS        | MATERIALS      | Q'TY | FINISH                   | ALL MATERIALS MUST BE COMPLIANT TO ROHS |                                      | APPD.                      | KANGXINAN                | 2004-7-26 |       |